

OFFICIAL ZONING MAP

- LEGEND**
- R-1 LOW DENSITY RESIDENTIAL
 - R-2 MEDIUM DENSITY RESIDENTIAL
 - R-3 RESIDENTIAL / LIGHT COMMERCIAL
 - PD PLANNED DEVELOPMENT
 - CF COMMERCIAL FRINGE
 - CD COMMERCIAL DOWNTOWN
 - IC INDUSTRIAL/COMMERCIAL
 - I INDUSTRIAL

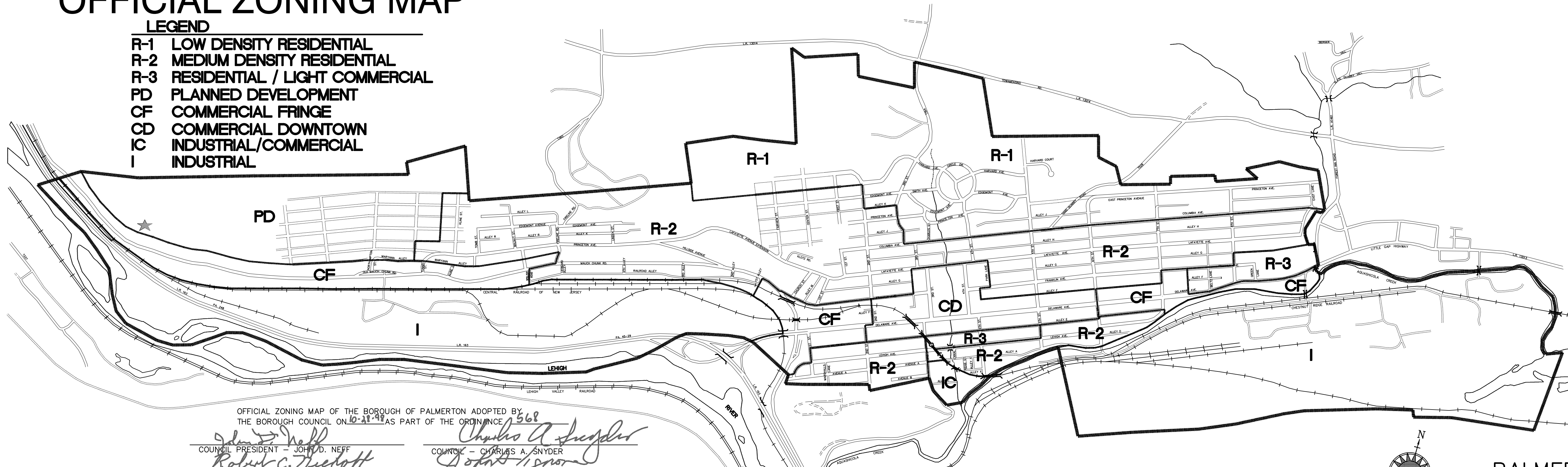

★ ZONING BOUNDARY IS 250 FEET FROM THE EXISTING ROAD RIGHT-OF-WAY LINE

OFFICIAL ZONING MAP OF THE BOROUGH OF PALMERTON ADOPTED BY THE BOROUGH COUNCIL ON 10-21-98 AS PART OF THE ORDINANCE 568

<i>John D. Neff</i> COUNCIL PRESIDENT - JOHN D. NEFF	<i>Charles A. Snyder</i> COUNCIL - CHARLES A. SNYDER
<i>Robert C. Niehoff</i> COUNCIL VICE PRESIDENT - ROBERT C. NIEHOFF	<i>John A. Vignone</i> COUNCIL - JOHN A. VIGNONE
<i>Robert E. Gruber</i> COUNCIL - ROBERT E. GRUBER	<i>Peter J. Delich</i> MAYOR - PETER J. DELICH
<i>Kenneth C. Jones, Jr.</i> COUNCIL - KENNETH C. JONES, JR.	<i>Rodger P. Danielson</i> MANAGER/SECRETARY - RODGER P. DANIELSON
<i>Barry W. Scherer</i> COUNCIL - BARRY W. SCHERER	<i>Michael L. Ozalas</i> SOLICITOR - MICHAEL L. OZALAS, ESQ.

NOTE: ZONING BOUNDARY LINES ARE FOR VISUAL REFERENCE ONLY. (SEE SECTION 304 OF THE ZONING ORDINANCE FOR ADDITIONAL INFORMATION.)

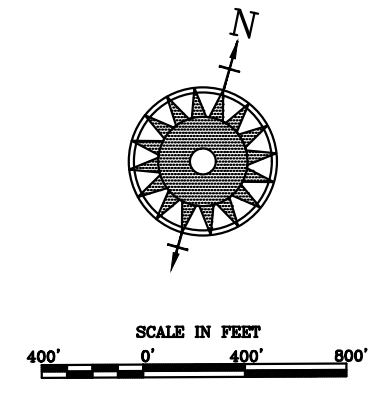

**PALMERTON BOROUGH
CARBON COUNTY, PENNSYLVANIA**

R.K.R. Hess Associates
Surveyors, Planners, Engineers, Architects
Landscape Architects, and Environmentalists
112 N. Courland St. P.O. Box 268, E. Stroudsburg, Pa. 18301
Telephone (717) 421-1550 Fax (717) 421-6720