

OFFICE OF
COUNCIL PRESIDENT

OFFICE OF
THE MANAGER

Borough of Palmerton

443 DELAWARE AVENUE
CARBON COUNTY
PALMERTON, PA 18071
610-826-2505

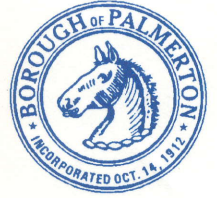

SIDEWALK CONSTRUCTION PERMIT

DATE: _____

PROPERTY ADDRESS: _____

PROPERTY OWNER: _____

DESCRIPTION OF WORK:

Sidewalk Construction
BUILDING PERMIT REQUIRED

Sidewalk Reconstruction

Curb Construction
BUILDING PERMIT REQUIRED

Curb Reconstruction

LOCATION OF WORK: _____

The applicant acknowledges receipt of the sidewalk and curb construction and repair standards as adopted by the Palmerton Borough Council in Resolution No. 216-94.

Please remember to call Pennsylvania One-Call (800-242-1776) three working days prior to digging.

Applicant

Approval Date: _____

Borough Manager

PERMIT IS VALID FOR ONE YEAR FROM DATE OF ISSUANCE

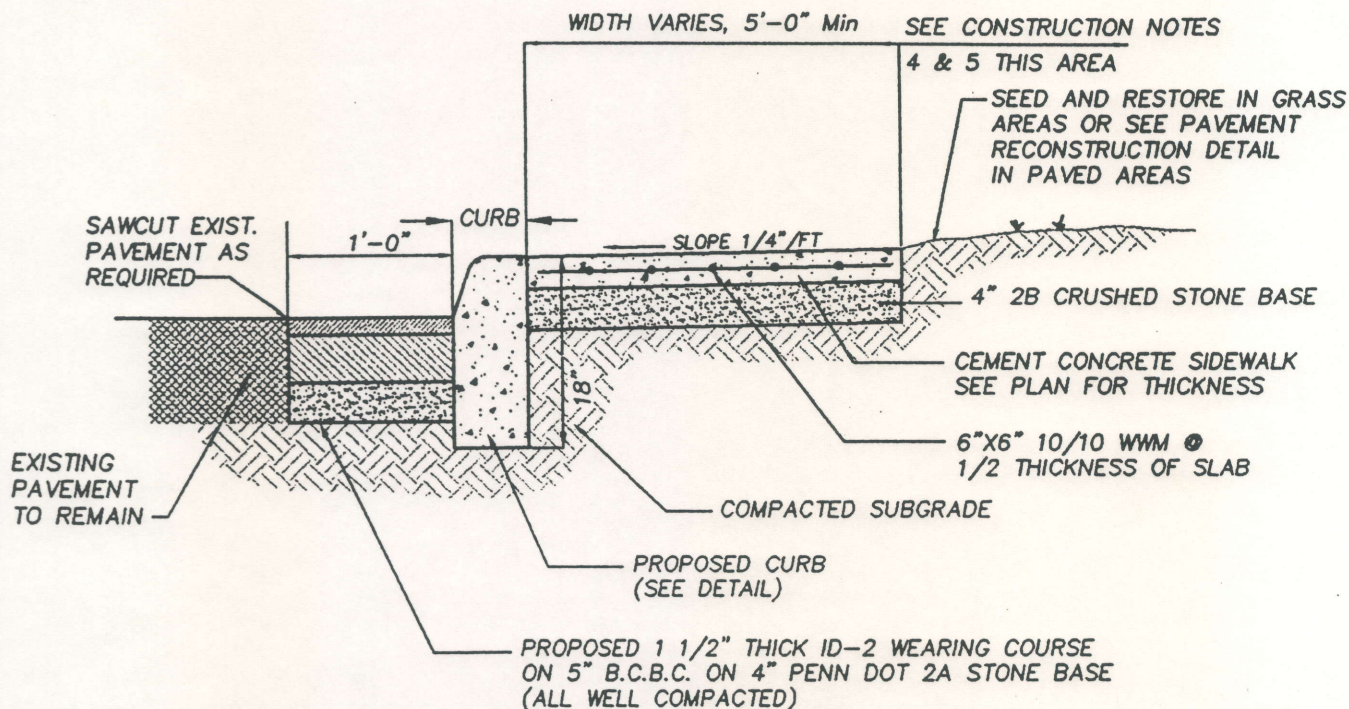

CURB/SIDEWALK CONSTRUCTION DETAIL

N.T.S.

TYPICAL SIDEWALK/CURB NOTES

1. CONCRETE CURB SHALL HAVE TRANSVERSE JOINTS AT LENGTHS NOT TO EXCEED 20 FEET WITH 3/4" EXPANSION JOINT MATERIAL
2. CONCRETE SIDEWALK SHALL HAVE SCORED TRANSVERSE JOINTS EVERY 5 FEET AND TRANSVERSE EXPANSION JOINTS WITH 3/4" EXPANSION JOINT MATERIAL EVERY 20 FEET.
3. PAVEMENT JOINT SEALER SHALL BE PLACED AT ALL FACE OF CURB/PAVEMENT JOINTS
4. ALL FINAL GRADES OF PROPOSED WORK SHALL EVENLY TIE INTO FINAL GRADES OF EXISTING SIDEWALK, CURB, PAVEMENT AND IMPROVEMENTS.
5. ALL TRANSITIONS FROM PROPOSED SIDEWALKS AND CURBS TO EXISTING WALKWAYS AND DRIVES SHALL BE A SMOOTH EVEN TRANSITION WITH MAXIMUM SLOPE OF 1" VERTICAL TO 12" HORIZONTAL.



R.K.R. Hess Associates
 Surveyors, Planners, Engineers, Architects
 Landscape Architects, and Environmentalists
 112 N. Courtland St. P.O. Box 268, E. Stroudsburg, Pa. 18301
 Telephone (717) 421-1550. Fax (717) 421-8720

CONSTRUCTION STANDARDS
 FOR
 BOROUGH OF PALMERTON

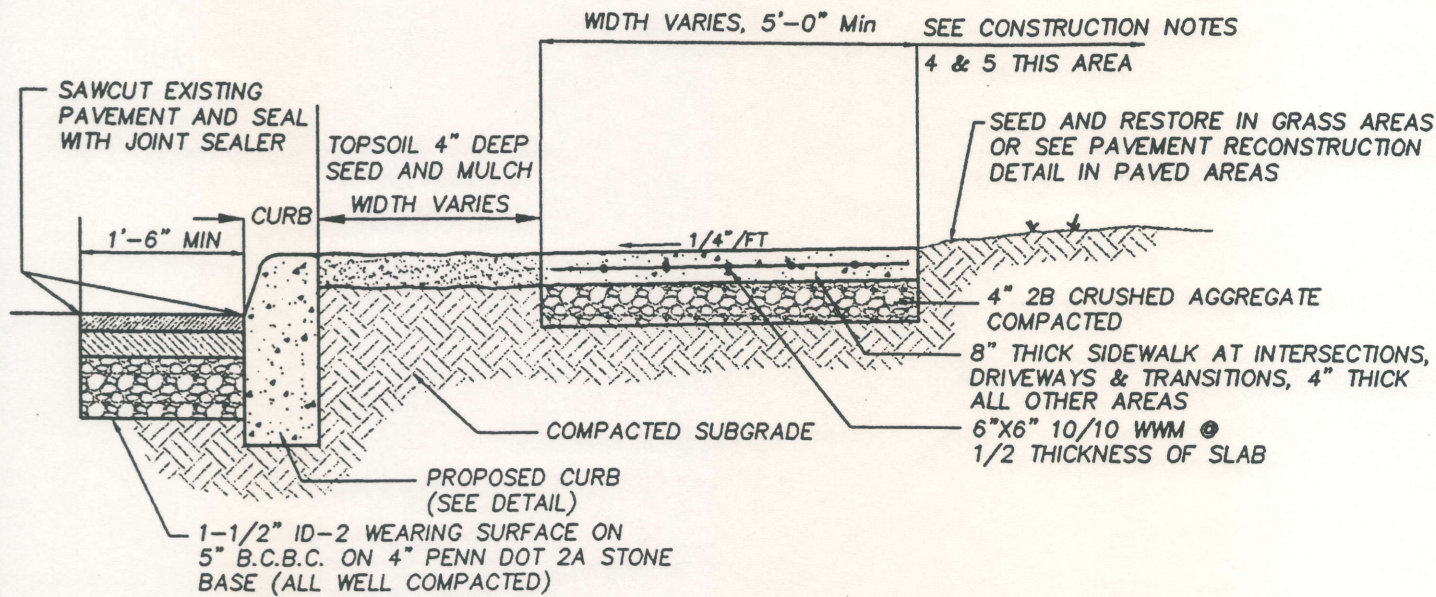

TYPICAL CURB/SIDEWALK CONSTRUCTION DETAIL WITH GRASS STRIP
N.T.S.

TYPICAL SIDEWALK/CURB NOTES

1. CONCRETE CURB SHALL HAVE TRANSVERSE JOINTS AT LENGTHS NOT TO EXCEED 20 FEET WITH 3/4" EXPANSION JOINT MATERIAL
2. CONCRETE SIDEWALK SHALL HAVE SCORED TRANSVERSE JOINTS EVERY 5 FEET AND TRANSVERSE EXPANSION JOINTS WITH 3/4" EXPANSION JOINT MATERIAL EVERY 20 FEET.
3. PAVEMENT JOINT SEALER SHALL BE PLACED AT ALL FACE OF CURB/PAVEMENT JOINTS
4. ALL FINAL GRADES OF PROPOSED WORK SHALL EVENLY TIE INTO FINAL GRADES OF EXISTING SIDEWALK, CURB, PAVEMENT AND IMPROVEMENTS.
5. ALL TRANSITIONS FROM PROPOSED SIDEWALKS AND CURBS TO EXISTING WALKWAYS AND DRIVES SHALL BE A SMOOTH EVEN TRANSITION WITH MAXIMUM SLOPE OF 1" VERTICAL TO 12" HORIZONTAL.



R.K.R. Hess Associates
 Surveyors, Planners, Engineers, Architects
 Landscape Architects, and Environmentalists
 112 N. Courtland St. P.O. Box 288, E. Stroudsburg, Pa. 18301
 Telephone (717) 421-1550. Fax (717) 421-6720

CONSTRUCTION STANDARDS
 FOR
 BOROUGH OF PALMERTON

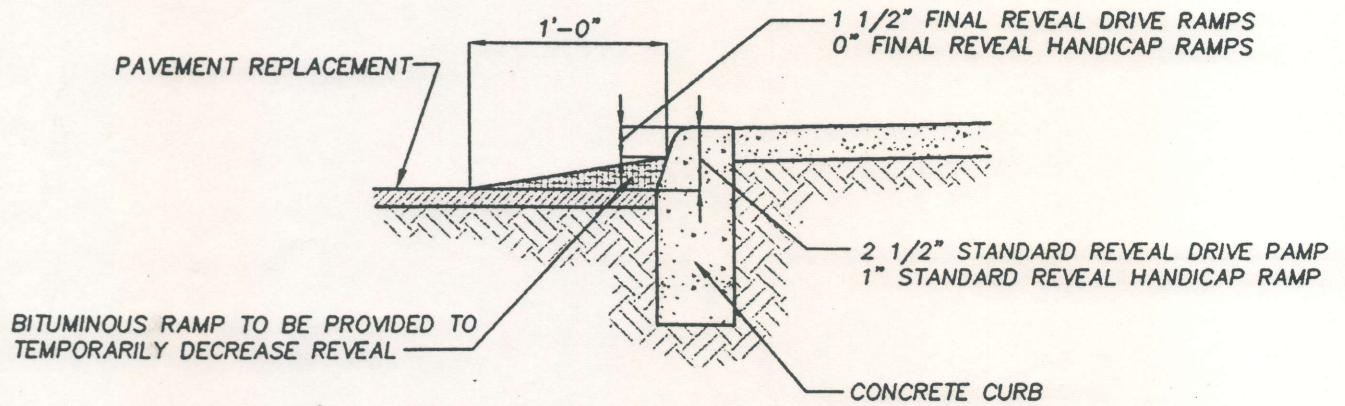

CURB BITUMINOUS RAMP DETAIL

N.T.S



R.K.R. Hess Associates
Surveyors, Planners, Engineers, Architects
Landscape Architects, and Environmentalists
112 N. Courtland St. P.O. Box 268, E. Stroudsburg, Pa. 18301
Telephone (717) 421-1650. Fax (717) 421-6720

CONSTRUCTION STANDARDS
FOR
BOROUGH OF PALMERTON

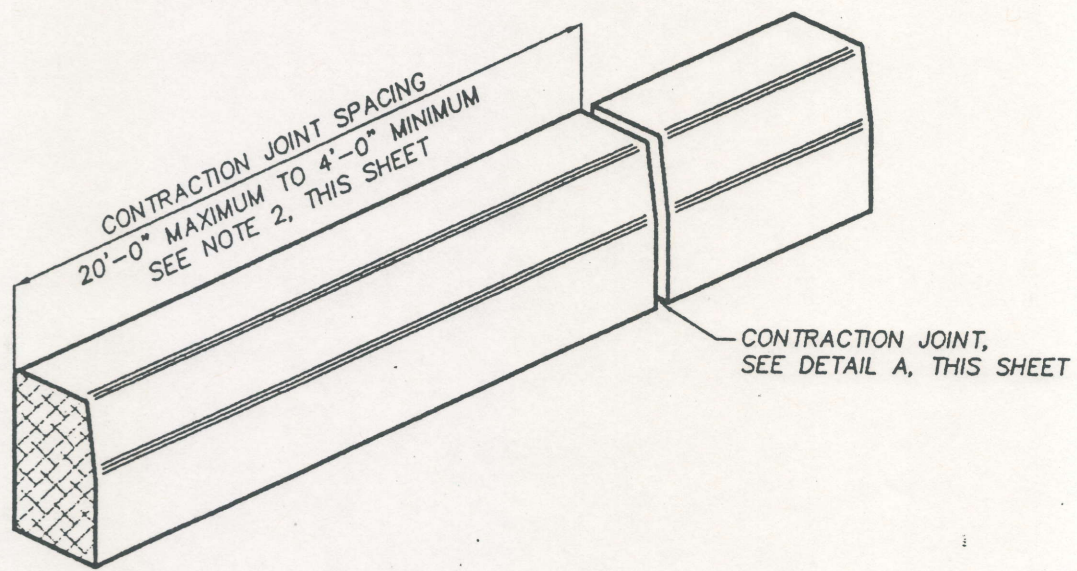
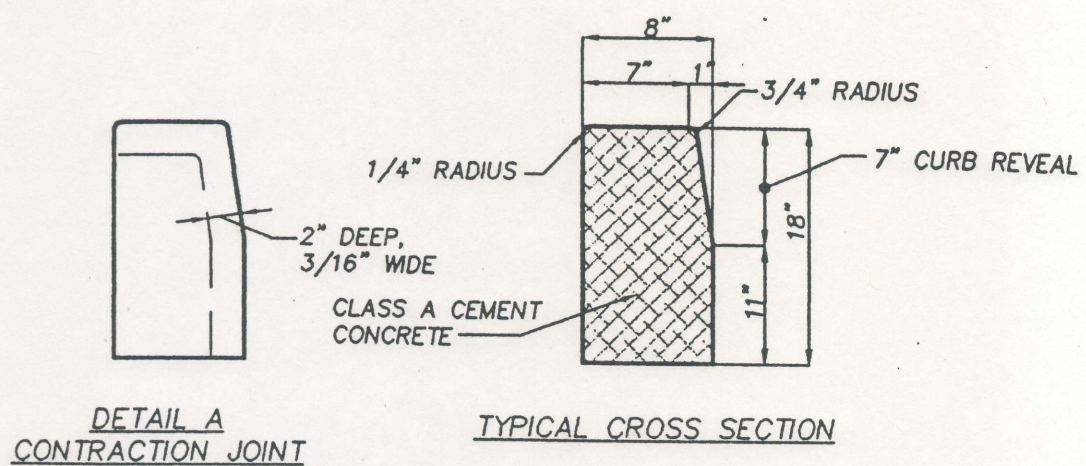

PLAIN CEMENT CONCRETE CURB

NOTES

1. MATERIALS AND CONSTRUCTION SHALL MEET THE REQUIREMENTS OF PUBLICATION 408, SECTION 630 FOR PLAIN CEMENT CONCRETE CURB, SECTION 640 FOR PLAIN CEMENT CONCRETE GUTTER, AND SECTION 641 FOR PLAIN CEMENT CONCRETE CURB GUTTER.
2. SPACE CONTRACTION JOINTS IN UNIFORM LENGTHS OR SECTIONS.
3. PLACE 3/4 INCH PREMOLDED EXPANSION JOINT FILLER MATERIAL AT STRUCTURES AND AT THE END OF THE WORK DAY. CUT MATERIAL TO CONFORM TO AREA ADJACENT TO CURB OR TO CONFORM TO CROSS SECTIONAL AREA OF CURB.

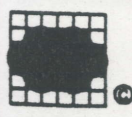

R.K.R. Hess Associates
 Surveyors, Planners, Engineers, Architects
 Landscape Architects, and Environmentalists
 112 N. Courtland St. P.O. Box 268, E. Stroudsburg, Pa. 18301
 Telephone (717) 421-1550. Fax (717) 421-8720

CONSTRUCTION STANDARDS
 FOR
 BOROUGH OF PALMERTON

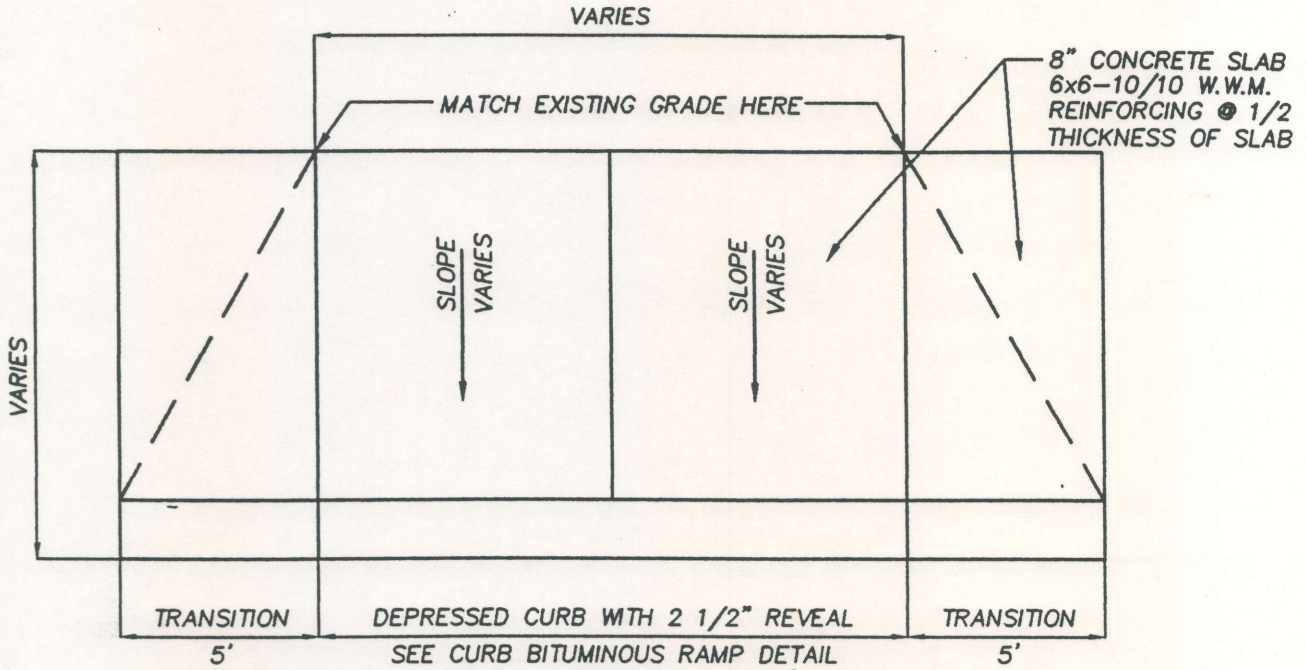

DRIVEWAY TRANSITION DETAIL
N.T.S



R.K.R. Hess Associates
Surveyors, Planners, Engineers, Architects
Landscape Architects, and Environmentalists
112 N. Courtland St. P.O. Box 268, E. Stroudsburg, Pa. 18301
Telephone (717) 421-1550. Fax (717) 421-6720

CONSTRUCTION STANDARDS
FOR
BOROUGH OF PALMERTON